

# SOPRASOLAR FIX EVO PEDESTAL

**SOPRASOLAR FIX EVO PEDESTAL** is an element of the **SOPRASOLAR FIX EVO** system (photovoltaic solar system integrated onto roof waterproofing).

## Description

The **SOPRASOLAR FIX EVO PEDESTAL** consists of a height-adjustable pedestal made from glass fibre reinforced polyamide which is mechanically fastened to a **SOPRASOLAR FLANGE**.

It facilitates the connection between the photovoltaic modules and the waterproofing system without perforating it.

## Constituent parts

	<b>SOPRASOLAR FLANGE 250</b>
Reinforcement	Non-woven polyester 250 g/m <sup>2</sup>
Elastomer bitumen binder	Mixture of bitumen and thermoplastic polymers SEBS
Min. thickness	4.7 mm
Dimensions	300 <sup>±1</sup> mm x 300 <sup>±1</sup> mm
Mass (indicative)	0.6 kg approx.
Top surface	Slate chippings
Interior surface	Hot melt film

	<b>ADJUSTABLE PEDESTAL</b>
Material	PA 6 GF30
Adjustable height	From 120 mm to 160 mm approx.
Fastening to fixing flange	4 Soprafix washers 4 stainless steel/ cap locknut M6 4 stainless steel washers 4 stainless steel grower washers
Min. bearing surface	Diameter 250 mm

## Caractéristiques

	<b>SOPRASOLAR FIX EVO PEDESTAL</b>
Dimensions (overall)	300 mm x 300 mm x 120-160 mm
Mass	1.3 kg approx.
Pull-off strength	1700 N
Resistance to outdoor conditions	All environments apart from mixed, aggressive or severe environments

		SOPRASOLAR FLANGE
Maximum tensile force (EN 12311-1) - Longitudinal - Transverse	MLV	800 N/5 cm 800 N/5 cm
Elongation at maximum load (EN 12311-1) - Longitudinal - Transverse	MLV	40 % 40 %
Resistance to nail tearing (N/mm <sup>2</sup> ) (EN 12310-1) - Longitudinal - Transverse	MLV	250 N 250 N
Flexibility at low temperature (EN 1109)	MLV	No cracking at -10 °C
Softening point (EN 1110)	MLV	95 °C
Static puncture resistance (NF P 84-352)	MLV	25 kg (L4)
Dynamic puncture resistance (NF P 84-353)	MLV	20 J (D3)
Peel resistance of joints with SOPRALENE FLAM 180 AR waterproofing membrane (EN 12316-1) - New - After ageing (28 days at 80 °C)	MLV	100 N/5 cm 100 N/5 cm

MLV : Manufacturer's Limit Value: minimum value liable to be provided under the quality system

## Use & application

The **SOPRASOLAR FIX EVO PEDESTALS** must be stored on a flat surface, protected from the weather and away from significant temperature variations.

**SOPRASOLAR FIX EVO PEDESTALS** must be installed in accordance with the recommendations of the **SOPRASOLAR FIX EVO** installation guide provided by **Soprasolar**.

## Specific information

### Health, safety and the environment:

The **SOPRASOLAR FIX EVO PEDESTALS** do not contain any hazardous components. Generally they meet all health, safety and environmental requirements.

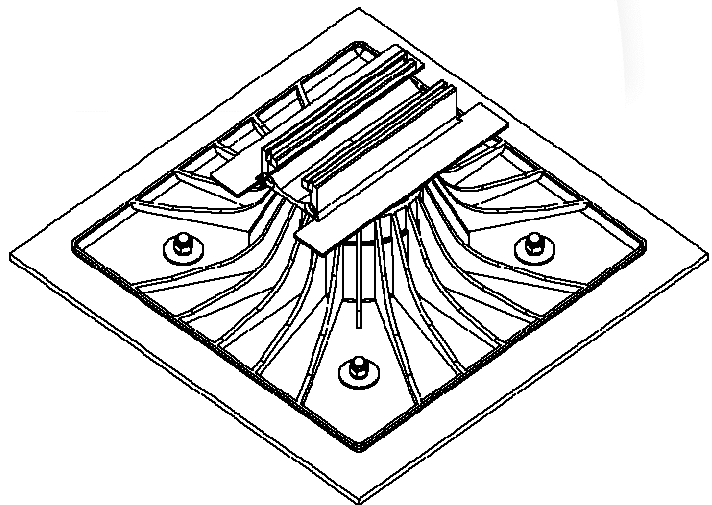
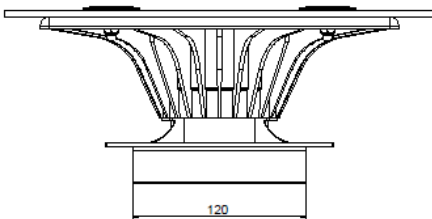
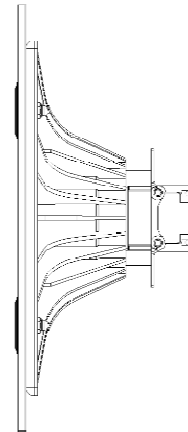
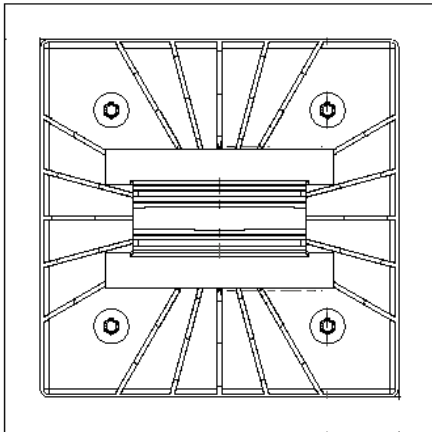
**Illustration**

SOPRASOLAR – 62, rue Transversale – F- 92238 GENNEVILLIERS CEDEX

Tel : +33 (0)1 46 88 01 80 - Fax: +33 (0)1 46 88 01 89

[www.soprasolar.com](http://www.soprasolar.com) • E-mail : [contact@soprasolar.com](mailto:contact@soprasolar.com)

Soprema UK • COLCHESTER - Essex - C06 2NS • [www.soprema.co.uk](http://www.soprema.co.uk) • [info@soprema.co.uk](mailto:info@soprema.co.uk) • Tel. +44 08451 948 727

Soprema IRELAND • Tallaght - DUBLIN 24 • [www.soprema.ie](http://www.soprema.ie) • [info@soprema.ie](mailto:info@soprema.ie) • Tel. +353 01 405 77 96

**SOPREMA**  
GROUP